

Knud Thorborg
 Scan-Speak, Videbæk, Denmark, kt@scan-speak.dk

Measurement of the Advanced Loudspeaker Parameters using Curve-Fitting Method

Loudspeaker data sheets are normally based on the traditional small signal “Thiele-Small” parameters. In spite of the moving mass and the force factor being the best physically defined parameters different procedures also for these lead to a variety of results. In this paper it is shown how to obtain reliable advanced parameters by curve-fitting. Simulated curves according to the FDD/Semi-Inductance model for the dynamic loudspeaker are fitted to the measured impedance curves in magnitude and phase and charts showing very precise simulations confirm the validity of the model. This paper is a “follow up” to the previous paper “Traditional and Advanced Models for the Dynamic Loudspeaker”.

Introduction

The traditional derivation of the loudspeaker parameters calls for the measurement of resonance frequencies with high precision. Obtaining this is problematic due to nonlinearities in the compliance and damping in the suspension of the moving system. Bl and M_{MS} are physically well defined, but they suffer from being calculated on basis of not equally well defined resonances.

The traditional “added mass” method gives systematically too small masses due to the frequency dependence of the compliance (increasing toward lower frequencies).

Furthermore is the traditional derivation based on a model which is imperfect as mentioned in the previous paper what results in imperfect box simulations.

1. Curve-Fitting as Means to Well Defined Advanced Parameters

More well defined parameters are obtainable on basis of curve-fitting instead of the measurement at discrete frequencies. In this way the results do not depend on single point measurements, but on the relevant curve as a whole. This can be utilized to get more well defined traditional parameters, but in the following curve-fitting is used to obtain advanced parameters in accordance with the FDD/Semi-Inductance model (repeated here from the previous paper in Fig.1).

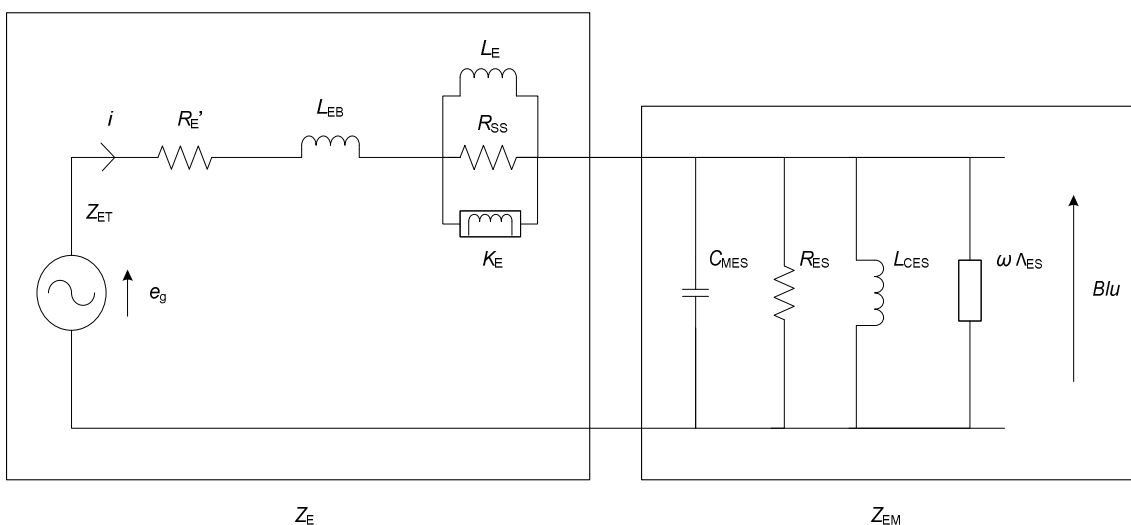

Fig. 1. The FDD/semi-induction model for the dynamic loudspeaker

Simulated curves in accordance with this model and the corresponding measured curves in magnitude and phase are shown (repeated too from the previous paper) in Fig.2 and 3

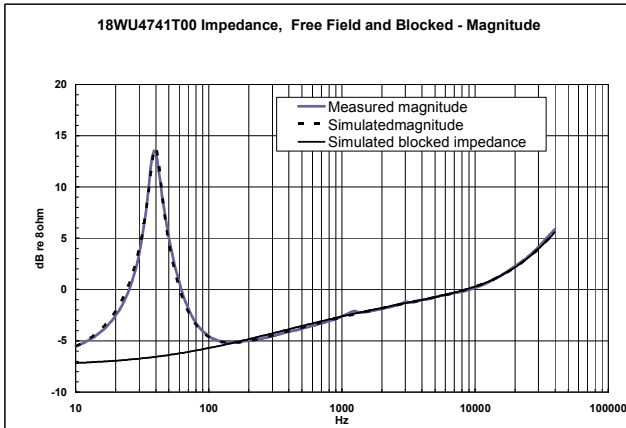

Fig. 2. Impedance, magnitude simulated according to the FDD model to the measured curve

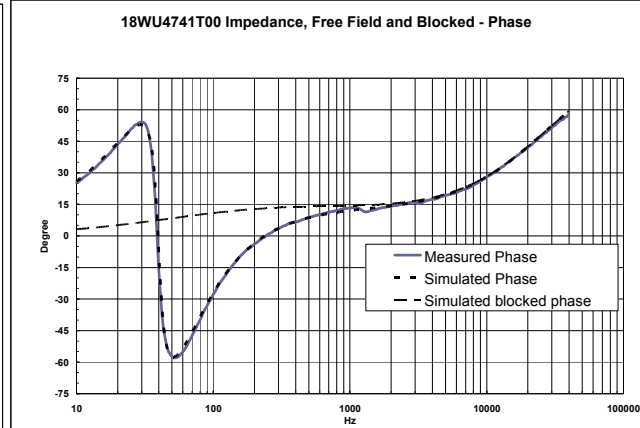

Fig.3. Same for the phase

It is the electrical parameters which are determined by this fitting. To derive M_{MS} and Bl the operation is repeated, now with a known added mass ΔM (with the electrical equivalent ΔC_{MES}) to the cone (the “Advanced Added Mass” method). Then M_{MS} and Bl are found as follows:

$$M_{MS} = \Delta M \cdot (C_{MES} / \Delta C_{MES}) \quad (1)$$

$$Bl = \sqrt{\frac{M_{MS}}{C_{MES}}} \quad (2)$$

Note that these equations do not imply C_{MS} or L_{CES} ; consequently the derivation is not disturbed by minor changes in the compliance.

2. Signal Source and Measurement Conditions

Loudspeakers in practice are generally driven from a low impedance source (amplifiers with negative feedback), but loudspeaker measurements are often executed using a constant current source, and this is not the most appropriate.

The magnetic damping, which at least for small signals is very linear, is inactivated. This means that the impedance peak is determined by Q_{MS} and not Q_{TS} , the mechanical instead of the much more regular total Q-factor. This results in large peak amplitudes and extra high velocities around the resonance - in particular for modern loudspeakers with low loss surrounds and non-conducting voice coil formers (which not like an aluminum voice-coil former contributes with damping, due to eddy current losses induced by its moving up and down in the dc-field in the air gap).

The result is that the measured impedance curves around resonance are deviating from the shape conforming to the model. This is caused by maximum in both amplitudes and velocities; amplitudes combined with the lacking tie on the nonlinearities in the compliance and damping, velocities softening the suspension caused by “thixotropy”.

(Thixotropy is known from gels having high viscosity when undisturbed, but much lower when stirred. If a loudspeaker is “played in” at high level, the resonance is lowered, but falls back in short time, so it is relevant to talk about “thixotropy” in a loudspeaker suspension).

These factors result in compliance softer around resonance and misshapen impedance curves. This results in less satisfying fits and an imprecise derivation of parameters.

The measurements presented here are measured using B&K 2012. Output is constant voltage in series with 50 ohm. The loudspeaker is “looking into” 50 ohm what is already a step in the right direction. If the 50 ohm is not sufficiently low the loudspeaker is shunted by a suitable resistance. Afterwards the computer program removes influence of the shunt and the result is impedance curves in much better agreement with the model. (Risk is loading the B&K2012 output with too low impedance in particular giving phase errors at top frequencies). The curves in Fig.2 and 3 are based on a measurement with a 20 ohm shunt. The same measurement is basis for all the graphs in the following.

3. Actual Simulation Practice

A Microsoft Excel spreadsheet is prepared with columns representing step by step the complex equations corresponding to the model shown in Fig.1 with rows for each standard frequency (in 1/24 octave step) from 10Hz to 40kHz. Preliminary values are inserted for the variables and the resulting curves are shown graphically in magnitude and phase together with the measured curves.

For the presentation is chosen magnitude in dB/8 ohm and phase in degrees. Error functions are prepared and quality factors (least square sum of errors) for magnitude (in dB) and phase (in degrees). The sum of these (weighted to give same order of magnitude) are minimized using the Microsoft “Solver” function – through an iterating process the sum of quality factors are reduced getting the simulated curves gradually closer to the measured.

4. The Derived Motional and Blocked Impedances

The simulated total curves are now very close to the measured. They are the sum of the blocked impedance Z_{E-sim} and the motional impedance Z_{EM-sim} and both of these are available from the spreadsheet (“sim” for simulated and “meas” for measured and later “T” for total and “der” for derived). But the full truth is not predicted by the model. At very low frequencies for Z_E there is a transition of R_E to R_E' , but otherwise the electrical impedance is expected to follow the model. For the motional impedance the validity of the model is restricted to the “piston range”; the frequency range in which the loudspeaker cone can be regarded as a rigid piston. Above this range the motional impedance is reflecting the cone modes not included in the model (see Fig.3 and 4). In the total impedance these are more or less masked by the dominating electrical impedance, and most often only the first cone break up, the “rim resonance” is seen as an artefact in an otherwise smooth curve.

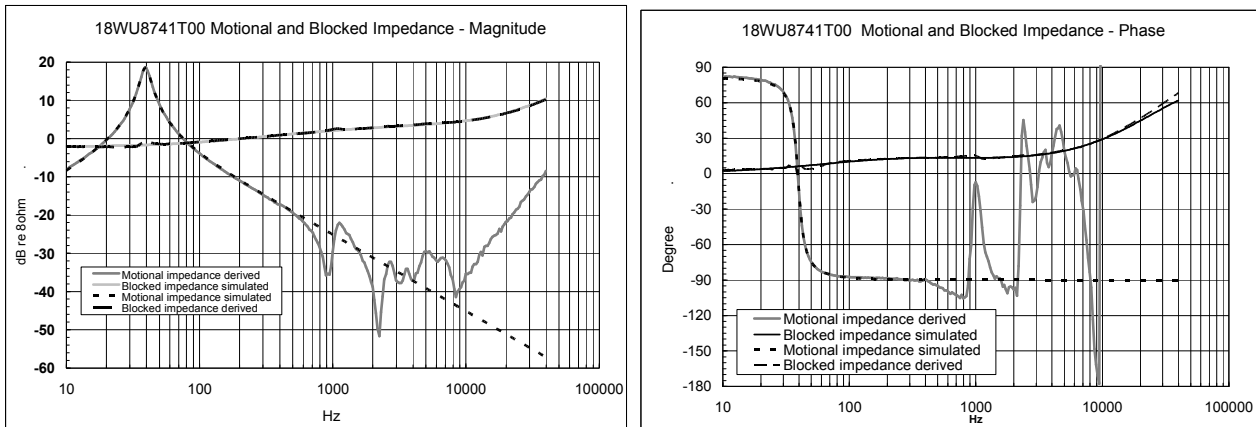

Fig.3 and 4. Derived and simulated motional and blocked impedances in magnitude and phase in the full frequency range.. Note the good agreement in the piston range and for the motional impedance derived the cone modes present in the curves

To derive well-defined loudspeaker parameters the piston range around resonance has special interest. For this purpose the “derived” blocked and the “derived” motional impedances are defined as follows:

$$Z_{E-der} = Z_{T-meas} - Z_{EM-sim} \quad (3)$$

$$Z_{EM-der} = Z_{T-meas} - Z_{E-sim} \quad (4)$$

New quality factors are established for Z_{E-der} fitted to Z_{E-sim} and for Z_{EM-der} fitted to Z_{EM-sim} . These are included in a total fitting, one total solving process (with/without added mass, all in all minimizing the sum of 12 quality factors) and the result is a very precise total fit –the extra quality factors give increased weight to the most important range where at the same time for a perfect measurement is expected to give perfect agreement with the model. Results are shown in Fig.2-3 and further in Fig.5-10.

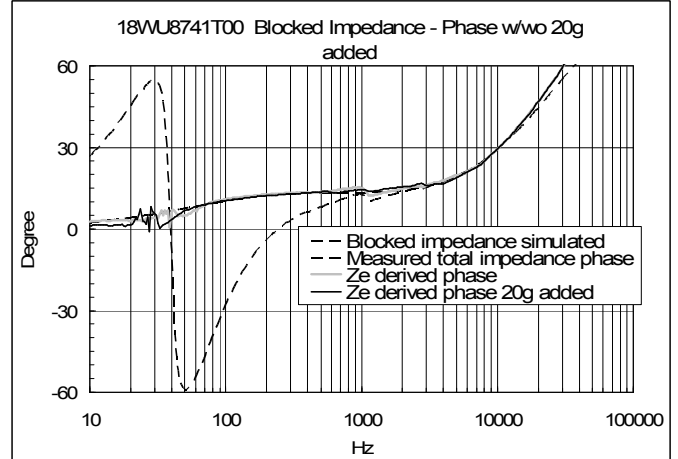
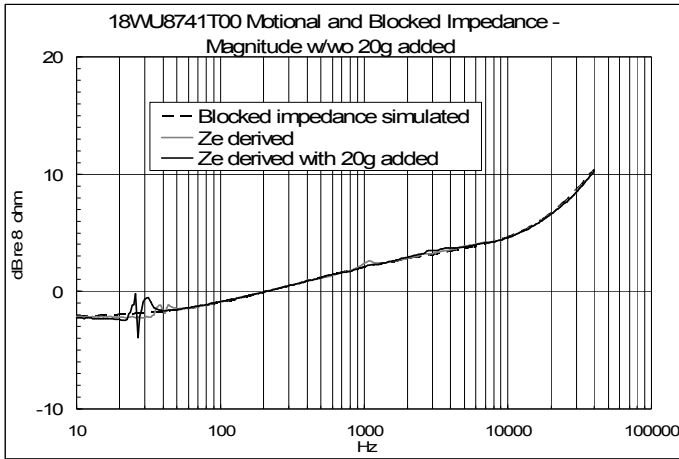

Fig.5 and 6. The derived and the simulated blocked impedances in magnitude and phase fitted to one another.

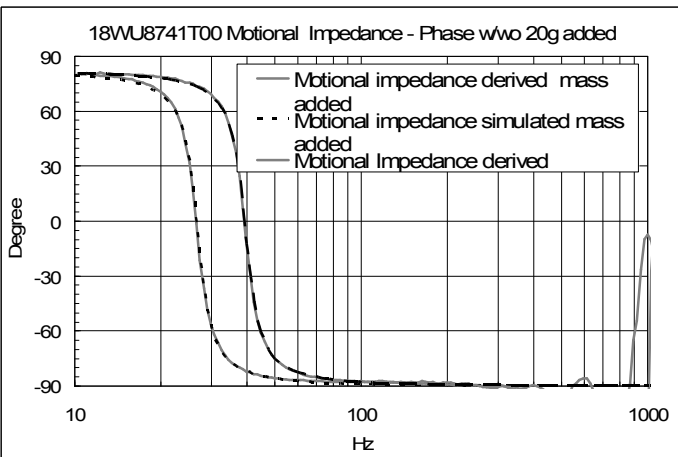
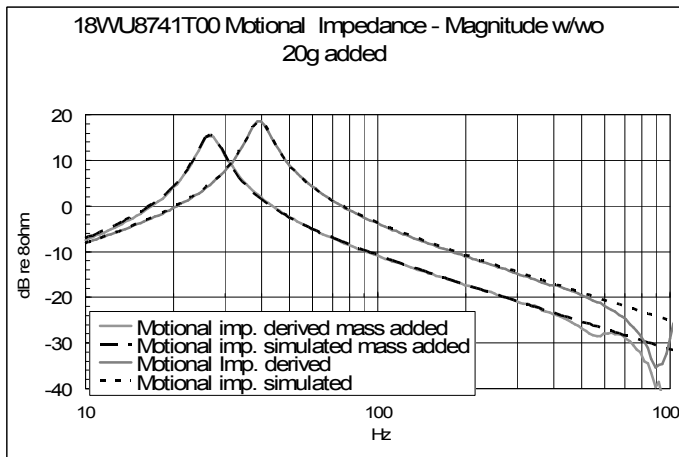

Fig. 7 and 8. Fitting the derived and the simulated motional impedances to one another in magnitude and phase with and without added mass 20 g

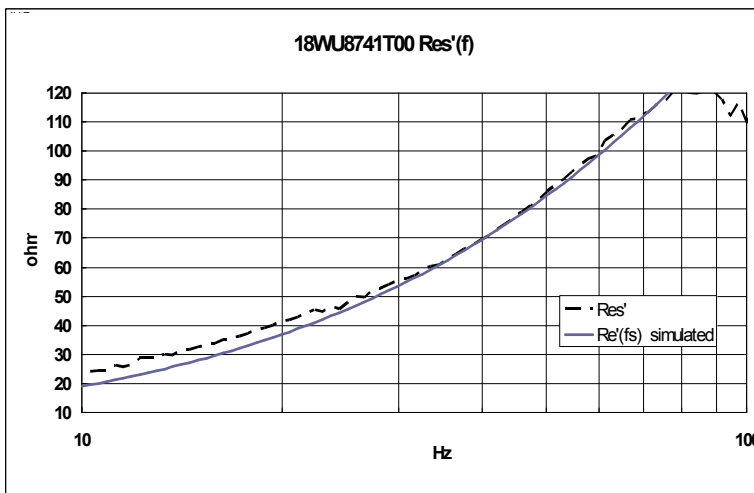

Fig.9. R_{ES}' derived from measurement compared to R_{ES}' according to the model Fig.1

The resulting damping resistance in the model Fig. 1 is $R_{ES}' = R_{ES} \parallel A_{ES}$. From the spreadsheet it is derived as $R_{ES}'_{der} = 1 / \text{Real}(Z_{EM-der})$ and it is seen that the agreement is good up to about $2f_s$, this is the frequency range in which the damping resistance plays a significant role.

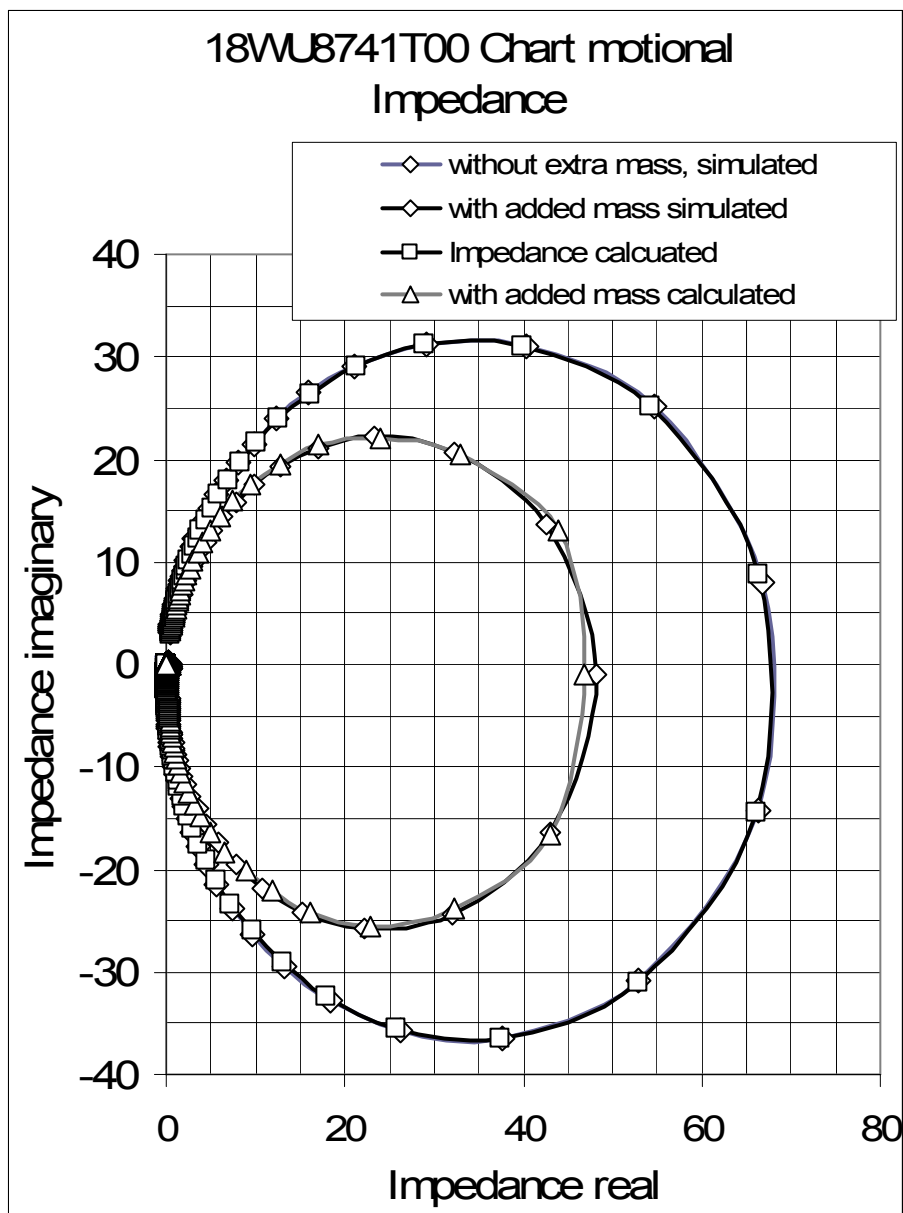

Fig.10. The impedance circle shows the agreement point for point of the simulated to the derived impedance in magnitude and phase.

Conclusion

The FDD/semi-inductance model for the loudspeaker is an important improvement compared to the traditional model dominating for the last 50 years. The new model works well for all loudspeakers measured up to date from dome tweeters to subwoofers. It is a model based on physical realities combining a very exact blocked impedance model with a model for the motional impedance taking the frequency dependence of the damping into account. This is estimated most significant, while the frequency dependence of the compliance is neglected. This last has minor influence in the audio frequency range (but can spoil traditional parameter measurements). However in a coming article in AES Journal the FDD model will be extended also to include this, but for practical use the FDD/semi-inductance model is an adequate and very precise tool.

To establish the data is maybe not simple sake, but if the loudspeaker manufacturer supplies these data the problem to insert them in a suitable box simulating program is just as simple as with the traditional model, but giving results remarkably more reliable.

Literature

- *K. Thorborg and Claus Futtrup: "Electrodynamic Transducer Model Incorporating Semi- Inductance and Means for Shorting AC Magnetization" J. Audio Eng. Soc. Vol. 59, No. 9, September 2011*
- *K. Thorborg, Carsten Tinggaard, Finn Agerkvist and Claus Futtrup: Frequency Dependence of Damping and Compliance in Loudspeaker Suspensions" J. Audio Eng. Soc. Vol. 58, No. 6. June 2010*
- *M, H. Knudsen and J. Grue Jensen: "Low-Frequency Loudspeaker Models That Include Suspension Creep" J. Audio Eng. Soc. Vol.41 , No. 12 January/February 1993.*
- *John Vanderkooy: "A Model of Loudspeaker Driver Impedance incorporating Eddy Currents in the Pole Structure", J. Audio Eng. Soc. Vol 37 March 1989*